



Ministère de l'Enseignement Primaire,  
Secondaire et Professionnel

# KUBALA NE KUFUNDA

Mukanda wa mulongi

CILUBA

3



Edition 2018



# KUBALA NE KUFUNDA

Mukanda wa mulongi



Direction des Programmes Scolaires et Matériel Didactique

## CIKEBELU

<b>MBANGILU</b> .....	1
<b>NTUADIJILU</b> .....	2

### **CITUPA 1 : NSOMBELU WA MUETU**

<b>Lumingu 1</b> : Musoko.....	4
<b>Lumingu 2</b> : Cimenga.....	8
<b>Lumingu 3</b> : Dibaka.....	12
<b>Lumingu 4</b> : Masanka a mapoloma.....	16
<b>Lumingu 5</b> : Mankenda a mubidi, a bilamba..ne a mu nzubu.....	20
<b>Lumingu 6</b> : Mankenda.....	24

### **CITUPA 2 : KUKUBA NYUNGULULU**

<b>Lumingu 8</b> : Cikuku-Biakudia.....	30
<b>Lumingu 9</b> : Biakunua.....	34
<b>Lumingu 10</b> : Metu ne mpata.....	38
<b>Lumingu 11</b> : Bia mu metu ne bia mu mpata .....	42
<b>Lumingu 12</b> : Bimuna.....	46
<b>Lumingu 13</b> : Nyama ya maitu.....	50

### **CITUPA 3 : KUYISHA DITUNGA KUMPALA**

<b>Lumingu 15</b> : Madimi.....	56
<b>Lumingu 16</b> : Midimu ya bianza.....	60
<b>Lumingu 17</b> : Njila.....	64
<b>Lumingu 18</b> : Biambula.....	68
<b>Lumingu 19</b> : Manaya a bankambua.....	72
<b>Lumingu 20</b> : Manaya a cinsangansanga.....	76

## MBANGILU

Kanungu 5 ka diyi dililombodi pa bulongeshanganyi bua mu Ditunga dia Kongo wa mungalata, tshiiapatshila tshia bulongeshi tshidi ditoyika dia muntu yonso bua kumuvuija muntu wa nsongo buende yeye ne bua nsombelu mulenga mu ditunga.

Bua kufika ku tshipatshila eci, ku ndekelu kua tulasa tupuekele, muana wa muena Kongo udi ne cia kumanya kubala, kufunda, kuenza makumi ; kumvua ne kukumbana kuakula biakane mu muakulu wetu wa bena Kongo ne mu mfualanse.

Kadi lelu eu, mulongi udi ujikija kalasa ka tshilongelu tshipuekele udi ne lutata luvule bua kubala ne kufunda ; kabidi mamanya adiyu mupete mu dilonga edi kaena afika ku tshipimu tshia matunga makuabu nansha.

Ebi mbijadikibue kumbukila ku bipeta bia ku mateta a mu ditunga bu mudi TENAFEP, ne kabidi mateta a ku matunga a ku babende bu mudi EGRA. Dipeta dishekeleke mu malongesha makuabu didi dimueneka se ndifumine ku dimanya dikese dia balongi mu dibala ne difunda.

Dishikuluja dibala ne difunda didi nkomeni udi ukengedibua bua dilonga diakane mu malongesha makuabu onso.

Bua kulongolola tshilema etshi, tshibambalu tshia dilongesha dia tulasa tupuekele , tubandile ne tua midimu ya bianza ntshiangata mapangadika a meji matue bua kulongolola mushindu wa kulongesha ne kulonga nangananga paditshi tshiangata dibala ne difunda tshidivuija dilongesha dijima pa mutu pa kushaladi anu ndambu wa diyisha tshianana.

Ke bualu kayi Tshibambalu tshia ndongeshelu wa tulasa tupuekele, tubandile ne tua midimu ya bianza tshidi tshiela tuasakidila tua manza tente kudi bisumbu bionso bitu bituala mpetu ne mambuluisa mashilangane ku didienzeja didibi bituala mu mudimu wa kubandisha ndongeshelu muakane ne bua bulongeshanganyi bua mu Kongo.

Mukanda ewu mmufunda ku bulongolodi bua Ndongamu ya tulasa ne bia kulongesha nabi pamue ne diambuluisa dia banyana batuadi ba mpetu mu citupa cia dilongesha ne dilonga dia kubala ne kufunda mu miakulu ya bena Kongo. Yoyi mikanda eyi idi ya tshibambalu tshia ndongeshelu wa tulasa tupuekele, tubandile ne tua midimu ya bianza. Mmifundila balongi ne balongeshi ba kalasa ka kumpala, kibidi ne kisu ba bilongelu bionso bia tulasa tupuekele tua mbulamatadi, bilongelu bia bisumbu bia Nzambi too ne ebi bia badikadile. Tudi tuela meji se bonso buabu ne badifile mu dibandisha ne dilongolola dia malongesha.

Balongeshi mbalombibue bua kuenzela biakane mukanda ewu wa kulongesha nawu bua kuenza se mudimu wabu ulue wa mushinga mukole bwa balongi.

*Gaston MUSEMENA BONGALA*  
*Mfumu mulombodi wa Tshibambalu tshia*  
*malongesha a tulasa tupuekele, tubandila ni tua*  
*midimu ya bianza*

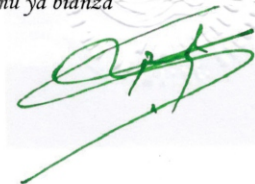

## NTUADIJILU

**M**ulombodi wa cibambalu cia tulasu tupuekele,tubandile ne tua midimu ya bianza mmuteka dibala ne difunda malongesha manene mu tulasu tupuekele bua kuikala mu lumvuanganyi lumue mu malu a tulasu ne matunga atudi nawu mutumba ne matunga a bulaba bujima.

Bua kuakaja ndongeshelu ne ndongelu wa dibala ne difunda mu tulasu tupuekele, cibambalu eci,ncipesha balongi ne balongeshi mukanda ewu udi upetangana ne poloKalama wa malongesha a mu ditunga dietu.

Mu kalasa ka kumpala ne kibidi Ciluba cidu muakulu udibu balongesha ne dilongesha. Mfualansa ndilongesha kadi ki mmuakulu wa ndongelu to.

Mu kalasa kisatu, mamanya a muakulu wa ditunga adi ambuluisa mulongi bua abangishe kulonga nfualanse . Dimanya dia maleta didi diambuluisa dipepeja dia kubala ne kufunda mu nfualanse pa lukasa. Miakulu yonso yibidi yidi yenda cia pamue. Pa nanku, bisumbu bisatu bia maleta ne bikuma biawu mbiobi ebi :

- Maleta ne bikuma biawu bia momumue ,
- Maleta ne bikuma biawu bifuanangane kadi kaayi abadibua mushindu umue to .
- Maleta ne bikuma bia pa buabi .

Difunda dia mukanda , kaye ka kubala ka mulongi ne mukanda wa mulongeshi,mbienzela pa dimanya dipiluke dia malu a bulongeshanganyi .

Mu bulondangane bua malongesha, tudi ne lumingu, tudi ne cieno bualu cidu ne malongesha asambombo mu mfulanse nansha mu miakulu ya bena Kongo. Dilongesha dia kumpala didi pa muyuki, dia ndekelu didi pa dikolesha dia mamanya adi bana bapete mu lumingu ne difunda.

Mukanda ewu , nciamua cia mudimu cimpe cieno bua kulongesha bana mua kubala ne kufunda.Tudi tulomba Balongeshi ne Baledi bua batue balongi mpanda bua bamone mua kulonga malu adi mu mukanda ewu.

**CITUPA CIA KUMPALA**

**NSOMBELU WA MUETU**

# MIABA

## Musoko

Ndi njoja ne ndi ngamba.

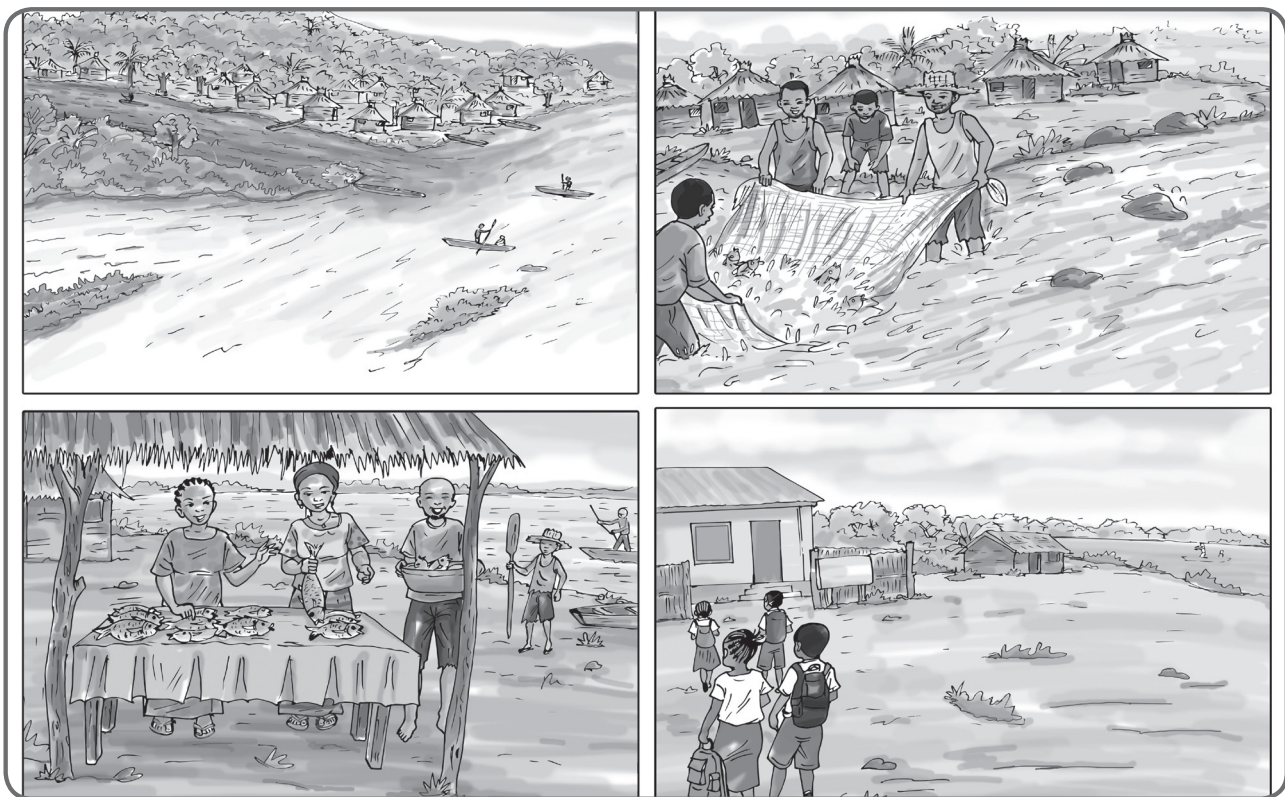





Kumbaja ciambilu eci:

1. Madimi a matala adi kumfundu kua ....

2. Musoko wetu udi ku muelelu wa ...

Funda pebe biebe biambilu bijadiki bibidi.

1. ....

2. ....



# MIABA

## Cimenga

Ndi njoja ne ndi ngamba.





Funda biambilu bijadiki bibidi bidi mu dibala dietu.

1. ....

2. ....

Funda pebe biebe biambilu bijadiki bibidi.

1. ....

2. ....

Funda dina dia ciwudi umona.

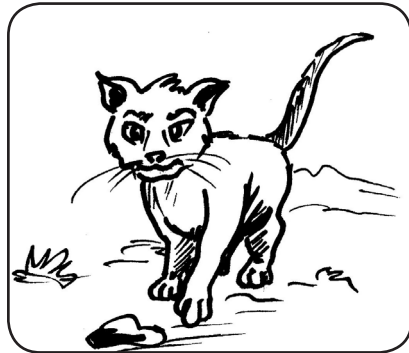
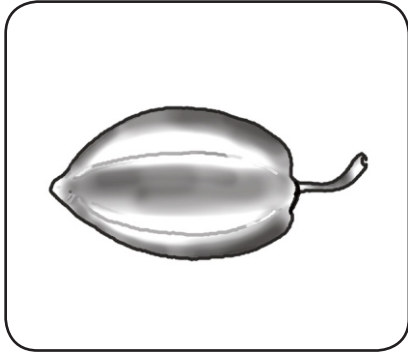

.....

.....

.....

Kumbaja ciambilu eci:

Musoko wetu udi.....

Funda biambilu bibidi pa musoko wenu.

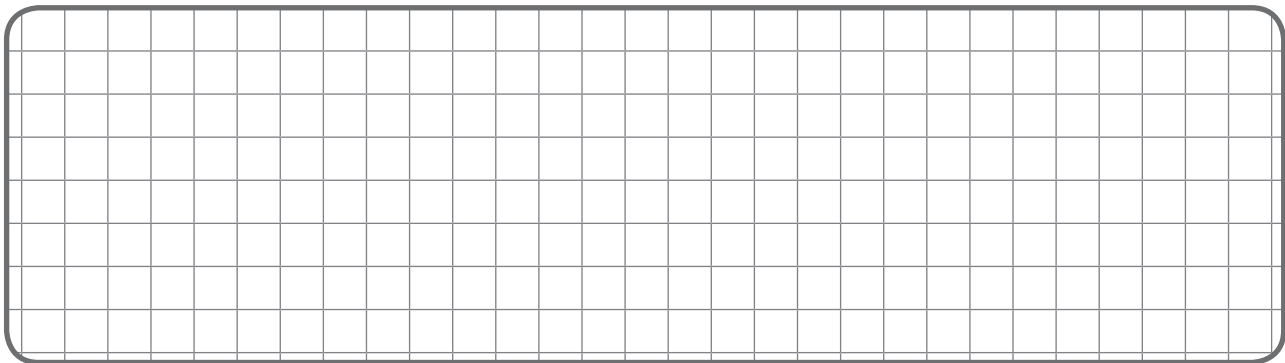

# Bibilu bia mu meku

Dibaka

Ndi njoja ne ndi ngamba.







Funda bibikidilu bisatu bidi bileja:

Muntu	Nyama	Bintu

Funda biambilu bibidi bidi bibenga bidi mu dibala.

1. ....
2. ....

Sungula mwaku udi kawuyi pa dibaka

dibaka
biuma
nzolu
ndundu
mbuji

Kumbaja ciambilu eci:

Mu dibaka ntu musue.....

Funda biambilu bisatu pa dibaka.

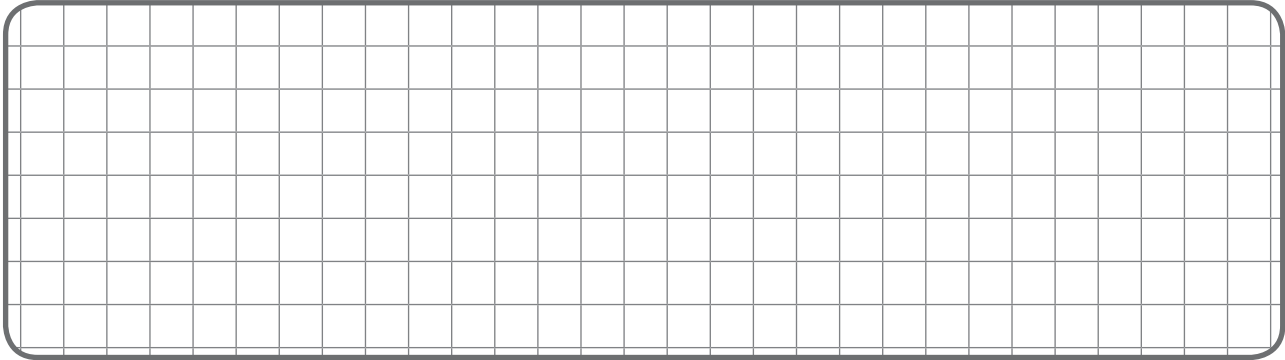

# Bibilu bia mu meku

## Cibilu

Ndi njoja ne ndi ngamba.





Muntu	Nyama	cintu

Funda biambilu bibidi bidi bibenga bidi mu dibala.

1. ....
2. ....
3. ....

Sungula muaku udi kawuyi mu dibala edi.

dipoloma
kalasa
baledi
budimi
mudimu
Babikidibue

Kumbaja ciambilu eci:

Kapinga udi muana wa bakaji wa.....

Funda biambilu bibidi pa cibilu cia dipoloma dia munganga Kapinga.

# Bukole bua mubidi

## Mankenda a mubidi, a bilamba

Ndi njoja ne ndi ngamba.

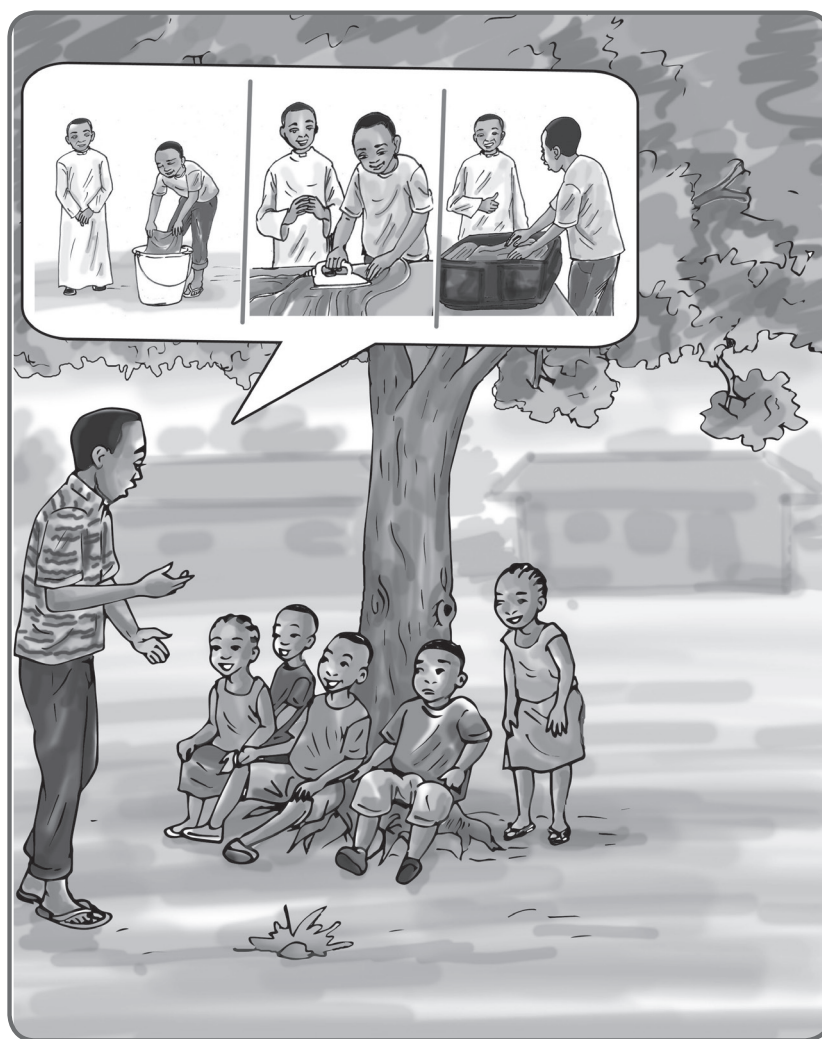





Funda bibikidilu bisatu bidi bifunkuna ne bia cibungi bidi mu dibala dietu.

Bibikidilu bifunkunyi	Bibikidilu bia cibungi

Funda pebe bibikidilu bisatu bifunkunyi ne bia cibungi.

1. ....
2. ....
3. ....

Funda miaku idi kayiyi pa mankenda.

Nsabanga
Mayi
Diba
Bilamba
Butuku

Kumbaja ciambilu eci:

Tutu towa mayi ne .....

Funda ciwutu wenza bua kuikala ne mankenda.

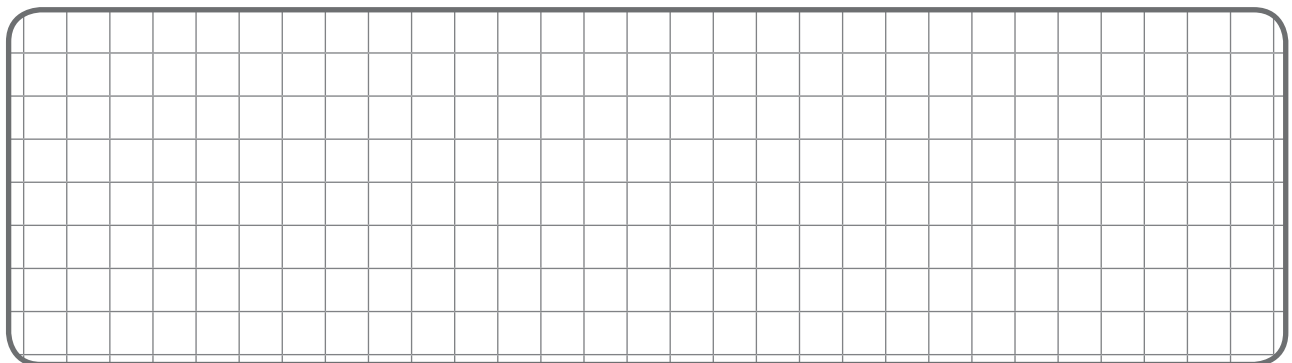

# Bukole bua mubidi

## Masama

Ndi njoja ne ndi ngamba.





Funda bibikidilu bia bantu, bia nyama ne bia bintu bidi mu dibala dietu.

bantu	nyama	bintu

Funda pebe bibikidilu bisatu bifunkunyi ne bia cibungi.

1. ....
2. ....
3. ....

Funda biambilu bitanu pa bukole bua mubidi.

1
2
3
4
5

Kumbaja ciambilu eci:

Mbuyi ne Kanku badi bowa.....

Funda biambilu bibidi pa masama.

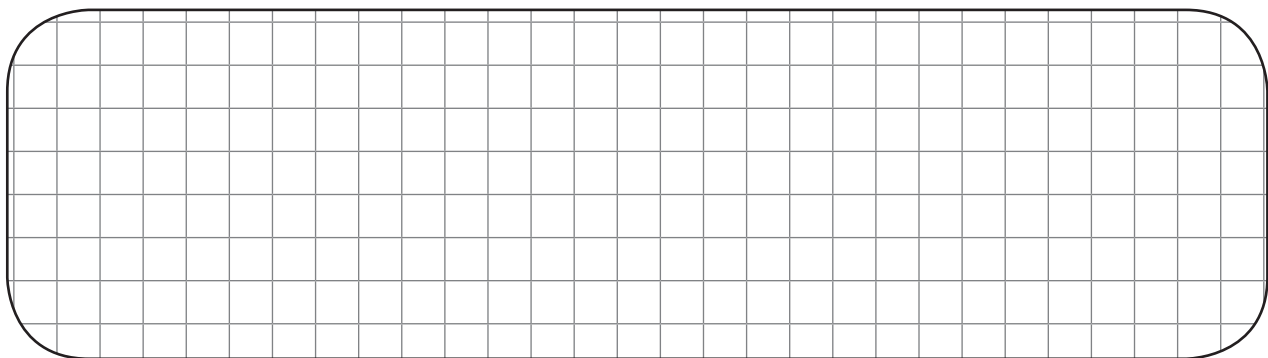





**CITUPA CIBIDI**

**KUKUBA NYUNGULUILU**

# Bidishi

## Biakudia

Ndi njoja ne ndi ngamba.





Funda ku bumue ni ku bungi

Ku bumue	Ku bungi
muntu	
	balongi
muana	
	balami
mukaji	



# Bidishi

## Biakunua

Ndi njoja ne ndi ngamba.

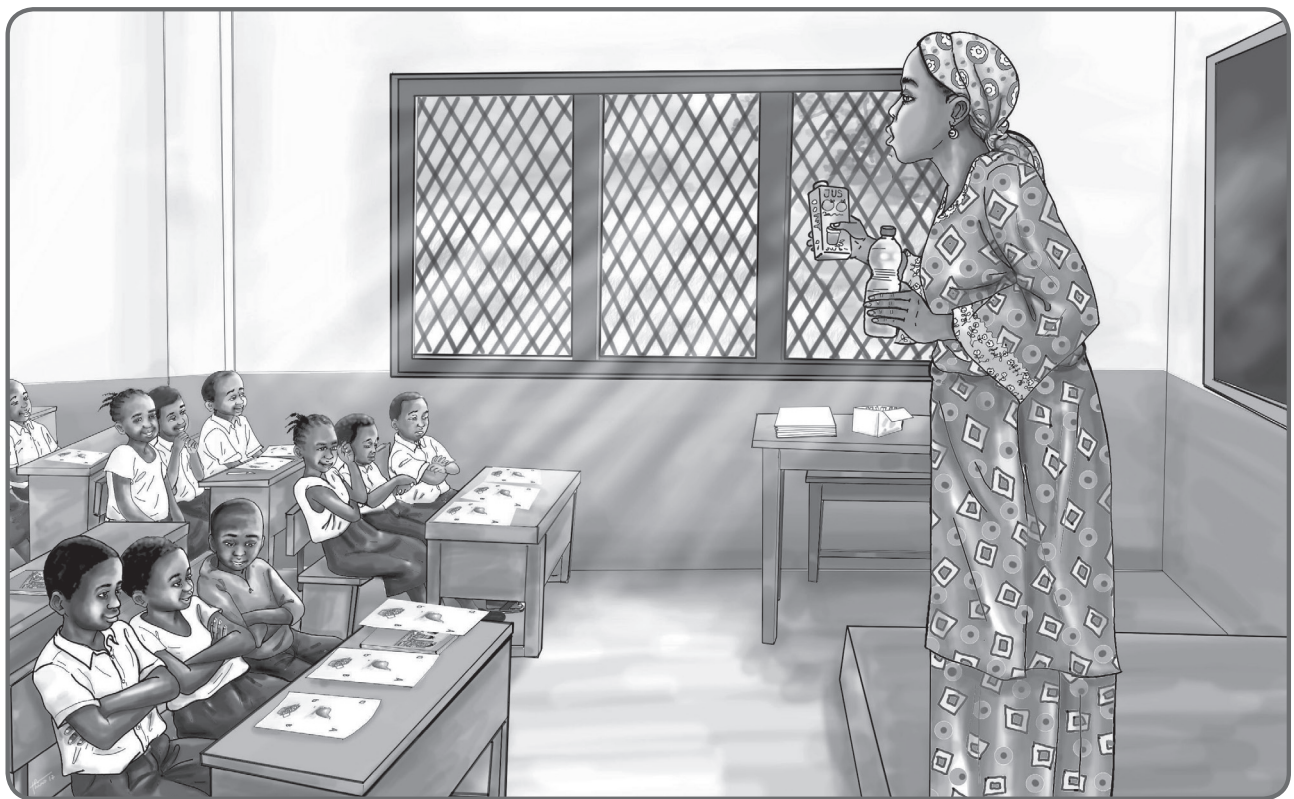

Ndi njoja.



Ndi mbala.

## Biakunua

Kabedi ne Kalala badi basumba bikaka.

Badi babisukula, bubula bizubu, pashishe babikosa.  
Kalala udi uzaza bikaka mu cinu.

Kabedi udi ukama mayi a bikaka. Badi baatumpa ne  
baela mu milangi.

Mukeba uvua musanke bua bungi bua mayi a  
bimuma. Badi ba apanyisha.

Ndi mfunda.

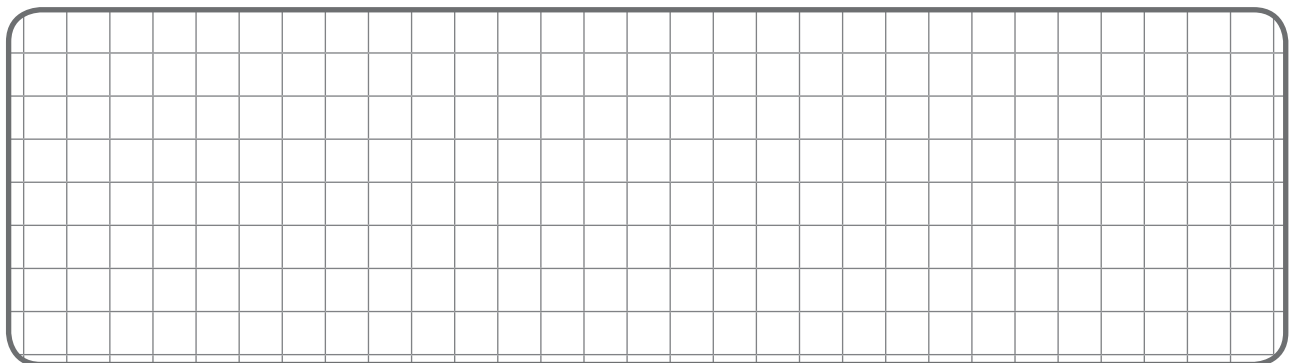

Funda miaku idi ku bumue ku bungi ne idi ku bungi uifunde ku bumue.

Ku bumue	Ku bungi
mulangi	
	mibelu
muci	
	mibanga
mutu	





# Metu ne mpata

## Kunowa

Ndi njoja ne ndi ngamba.

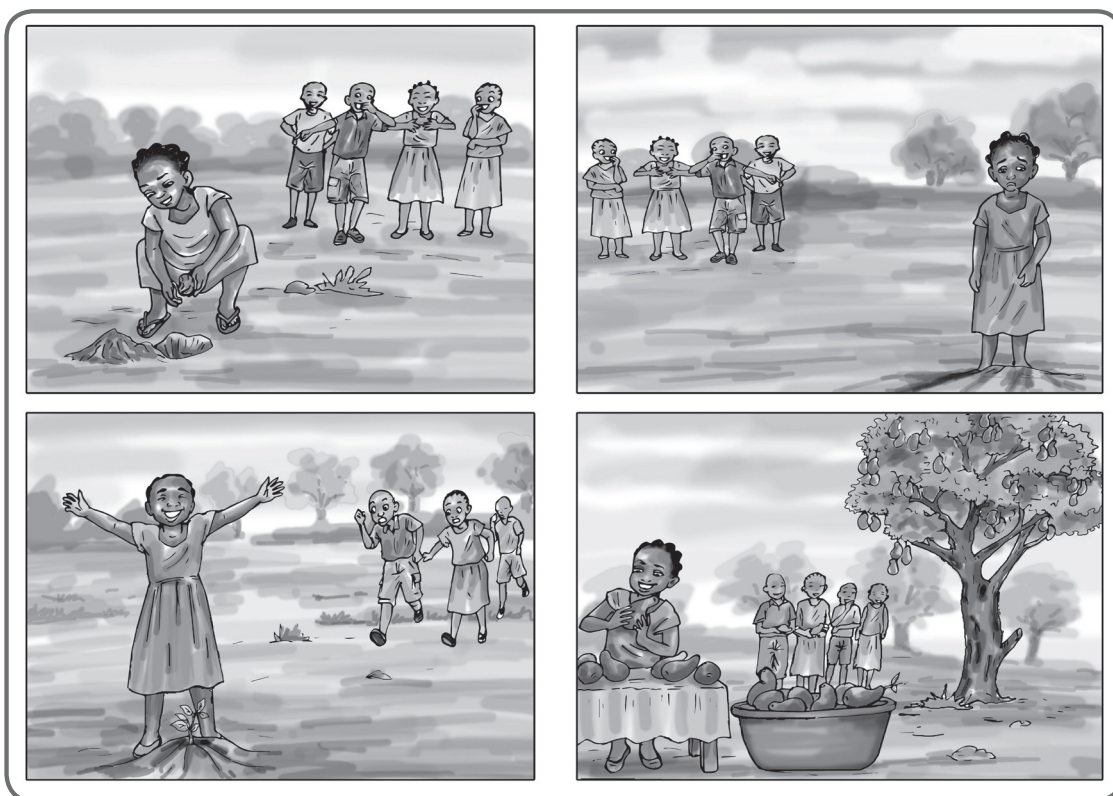



Funda miaku idi ku bumue ku bungi ne idi ku bungi uifunde ku bumue.

kubumue	Ku bungi
nzolo	
	njila
nzubu	
	ndungu
njiwu	

Ku miaku eyi yonso, mmuaku kayi udi kauyi pa bikunyibua.

muci
bimuma
avuka
mashinyi
Didima

Kumbaja ciambilu eci :

Kabedi udi ukuna.....  
Funda biambilu bibidi pa bikunyibua

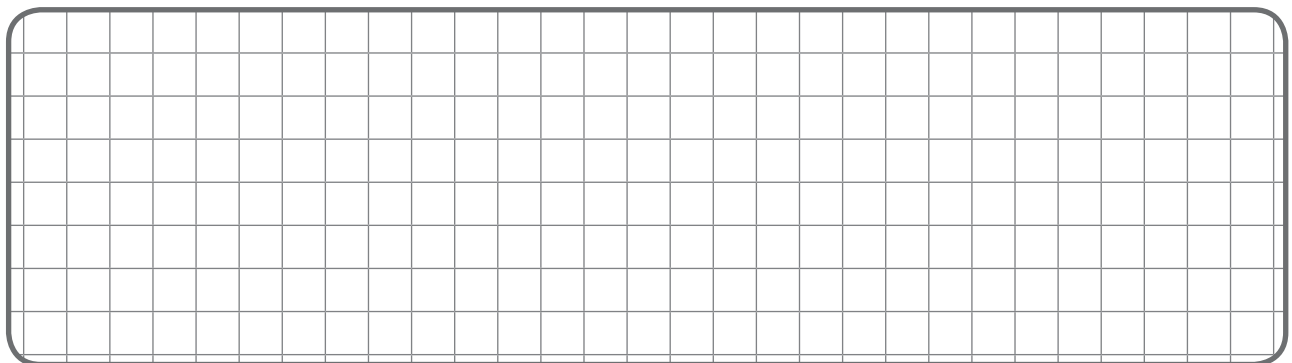

# Metu ne mpata

## Kukuba nyunguluilu

Ndi njoja ne ndi ngamba.





Fundayi ciena bualu cidi mu ciambilu cionso cidi mu dibala edi.

Ciena bualu
1.
2

Fundayi penu biambilu bidi ne ciena bualu.

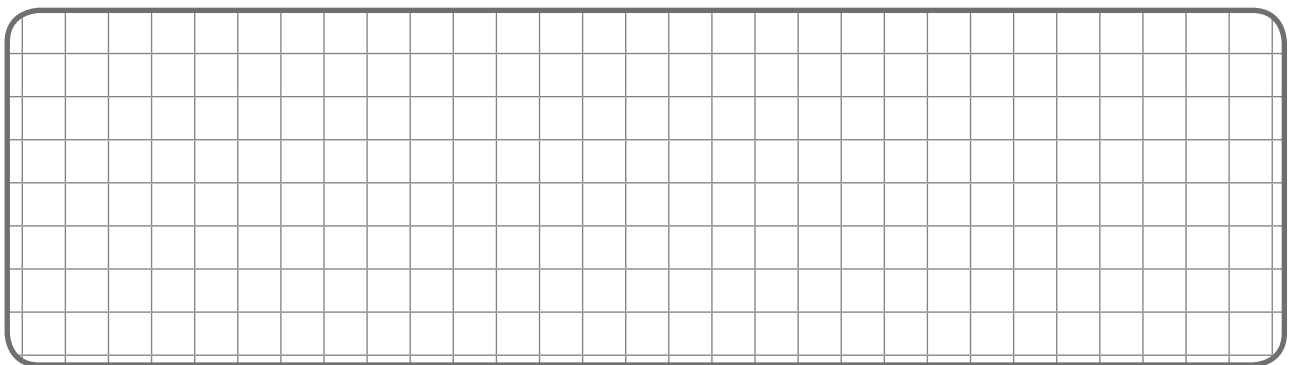



Funda muaku udi kauyi pa metu.

bimuma
bisuku
ditu
ndeke
miji

Kumbaja ciambilu eci :

Bua kulama metu, tulekelayi.....

Funda biambilu bibidi pa biutu wenza bua kulama metu.

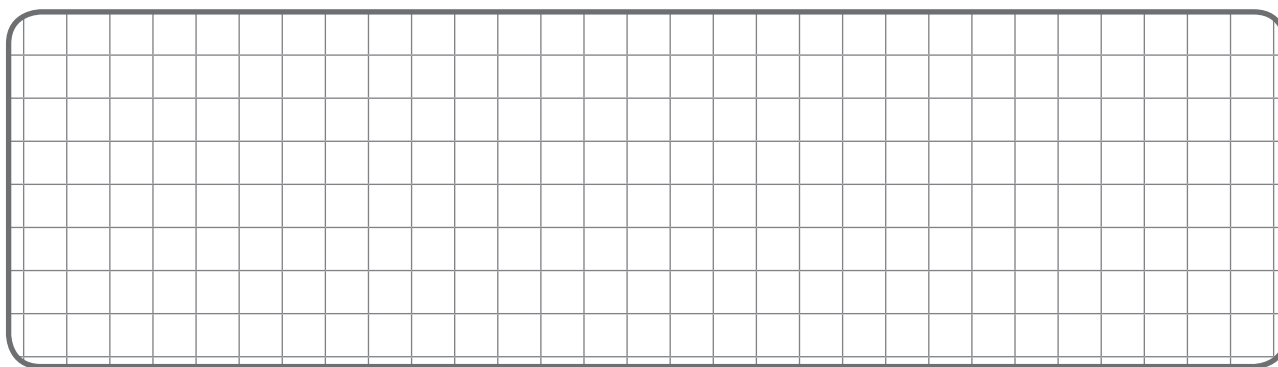

# Nyama

## Bimuna

Ndi njoja ne ndi ngamba.

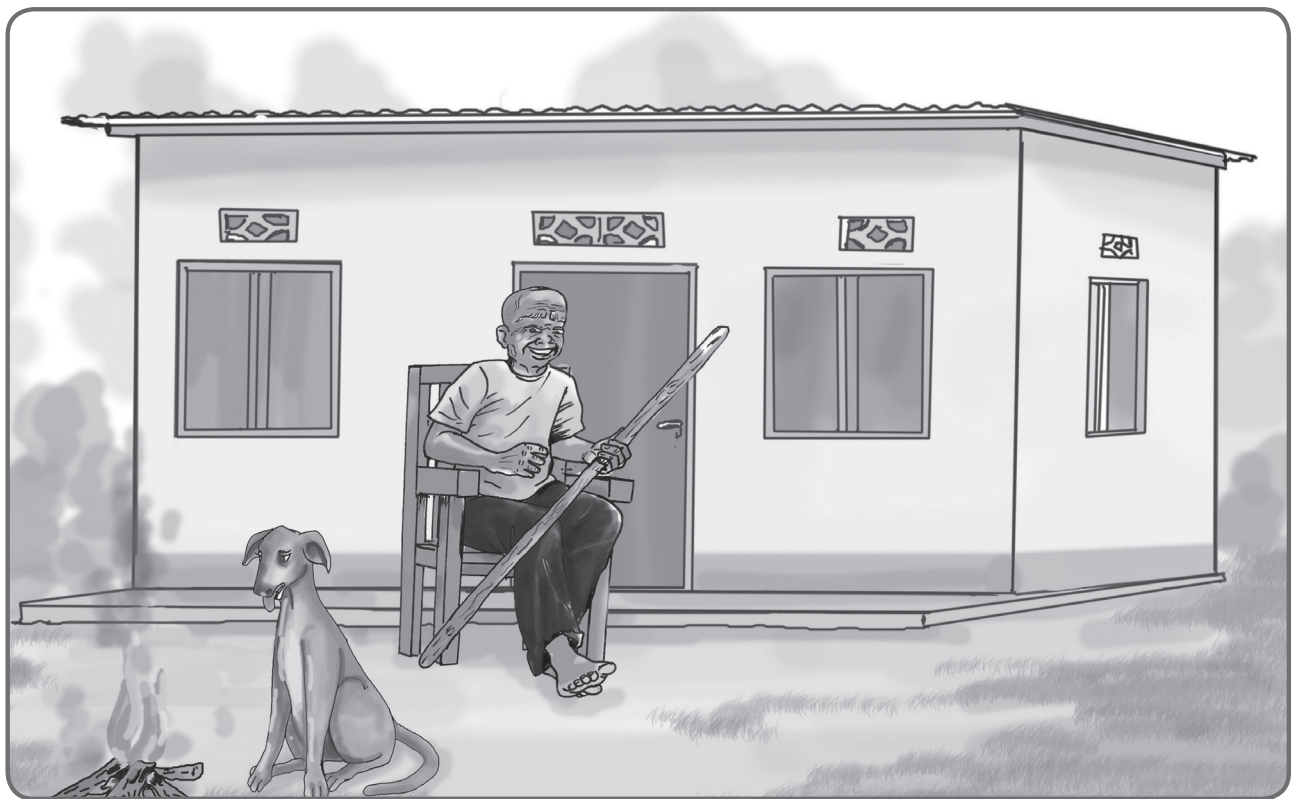

Ndi njoja.



Ndi mbala.

Mbua ne Muntu

Mbua uvua usomba muitu ; uvua mulunda wa Muntu. Muntu uvua uya diba dionso kutangila Mbua muitu.

Dikuabo dituku, Mbua kuambila mulunda wende ne : « Ndi musue kulua kukumona pambelu ». Awu pende ekuitaba.

Mbua uya kutangila Muntu, ekusangana bota kapia. Mbua kota kapia kunangidila, ekubengayi bua kupingana muitu.

Ndi mfunda bitu mbua wenzela muntu.

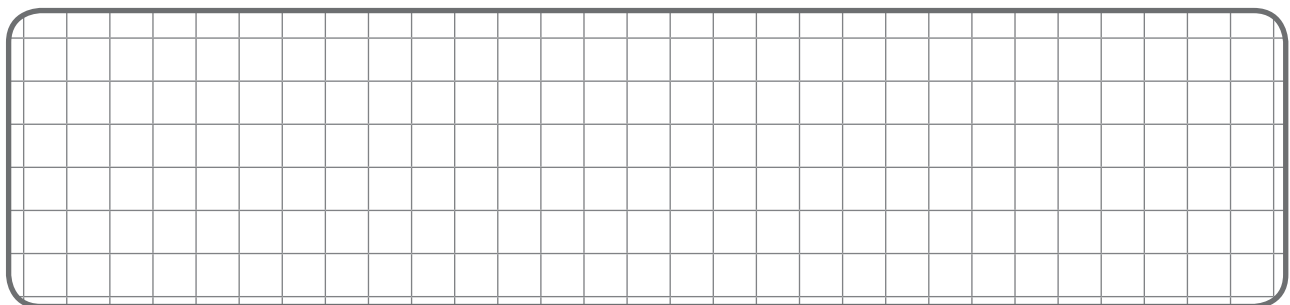

Fundayi miaku idi bikumbajilu mu biambilu bibidi bia ndekelu.mu dibala edi.

1.....
2.....



Fundayi penu biambilu bibidi bidi ne miaku mikumbaji.

1.....
2.....

Funda muaku udi kauyi pa bimuna.

mbua
nkudimba
cilongelu
nzolo
mbuji

Kumbaja ciambilu eci.

Ku nzubu tudi tumuna .....

Londa mu biambilu bibidi munutu numuna nyama kuenu.

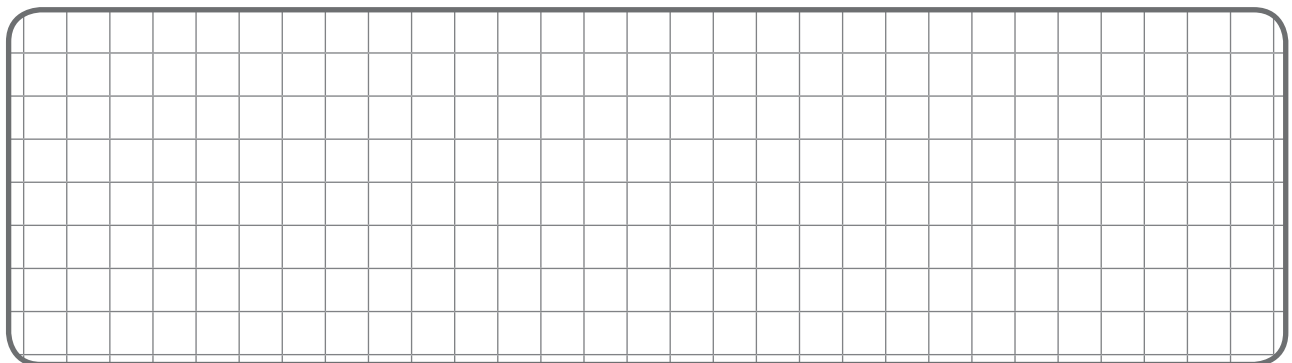

# Nyama

## Nyama ya ditu

Ndi njoja ne ndi ngamba.

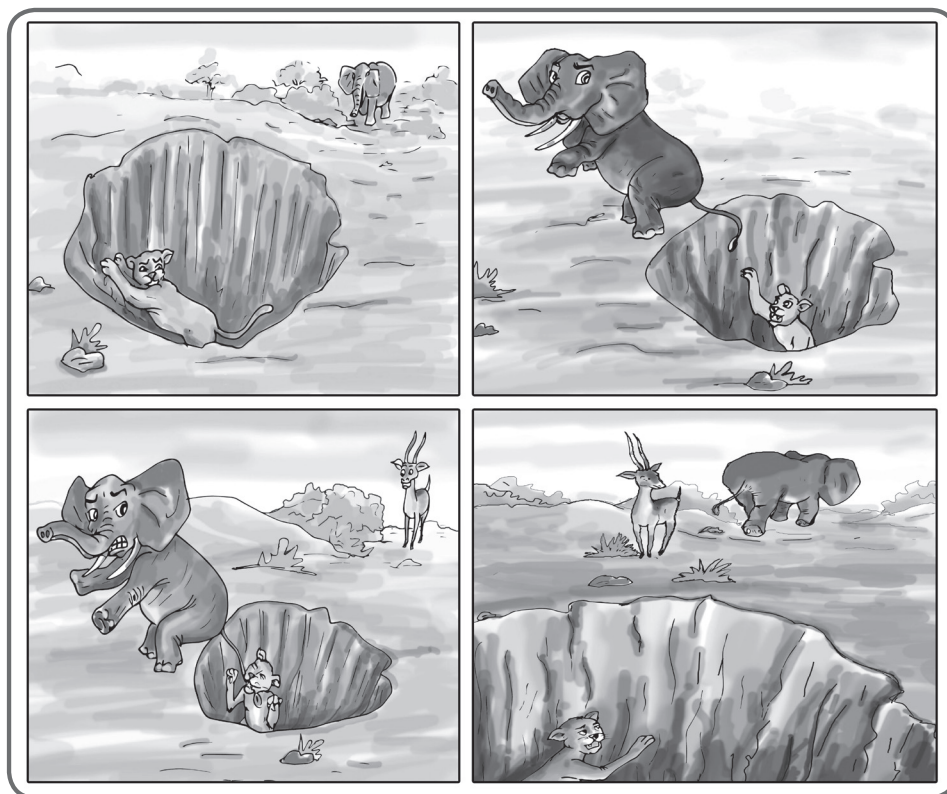

Ndi njoja.



Ndi mbala.

Cipangu cia bukua mpuku

Mu diyeba dia Kalombo mpuku iwwa idia matala.  
Kalombo wakanyingalala ekusumbaye Kambishi.

Kambishi kubanga kudia mpuku ya bungi.

Kambishi kubanga kudia mpuku mu diyeba.

Mpuku ekubelayi mu cipangu ne katulu kubutuka.

Mpuku yonso kunyema kambishi ekuyayi mu cisuku.

Amu nkosa ke wakashala mu nzubu mua muntu.

Ndi mfunda nyama isatu indi mumanye.

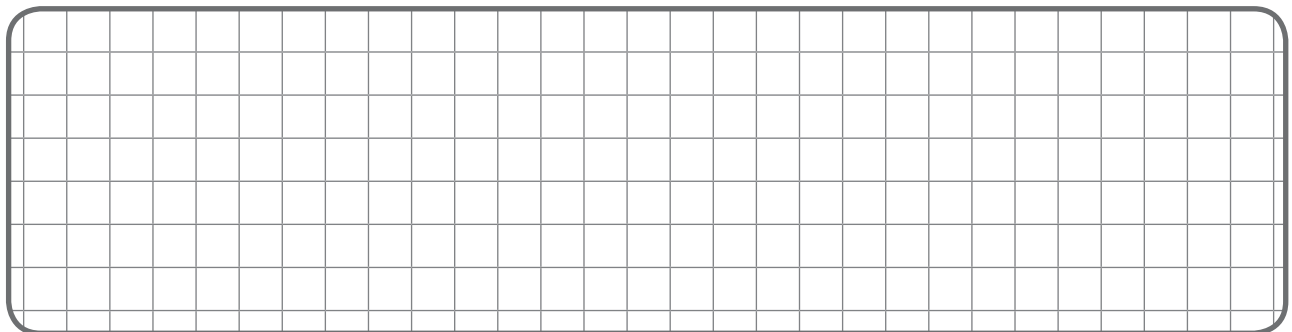

Fundayi biambilu ne cikumbajilu cia muku wa pamuanda.

1.....
2.....

Fundayi penu biambilu bibidi bidi ne miaku mikumbaji.

1.....
2.....







**CITUPA CISATU**  
**KUYISHA DITUNGA KUMPALA**

# Mudimu

## Madimi

Ndi njoja ne ndi ngamba.

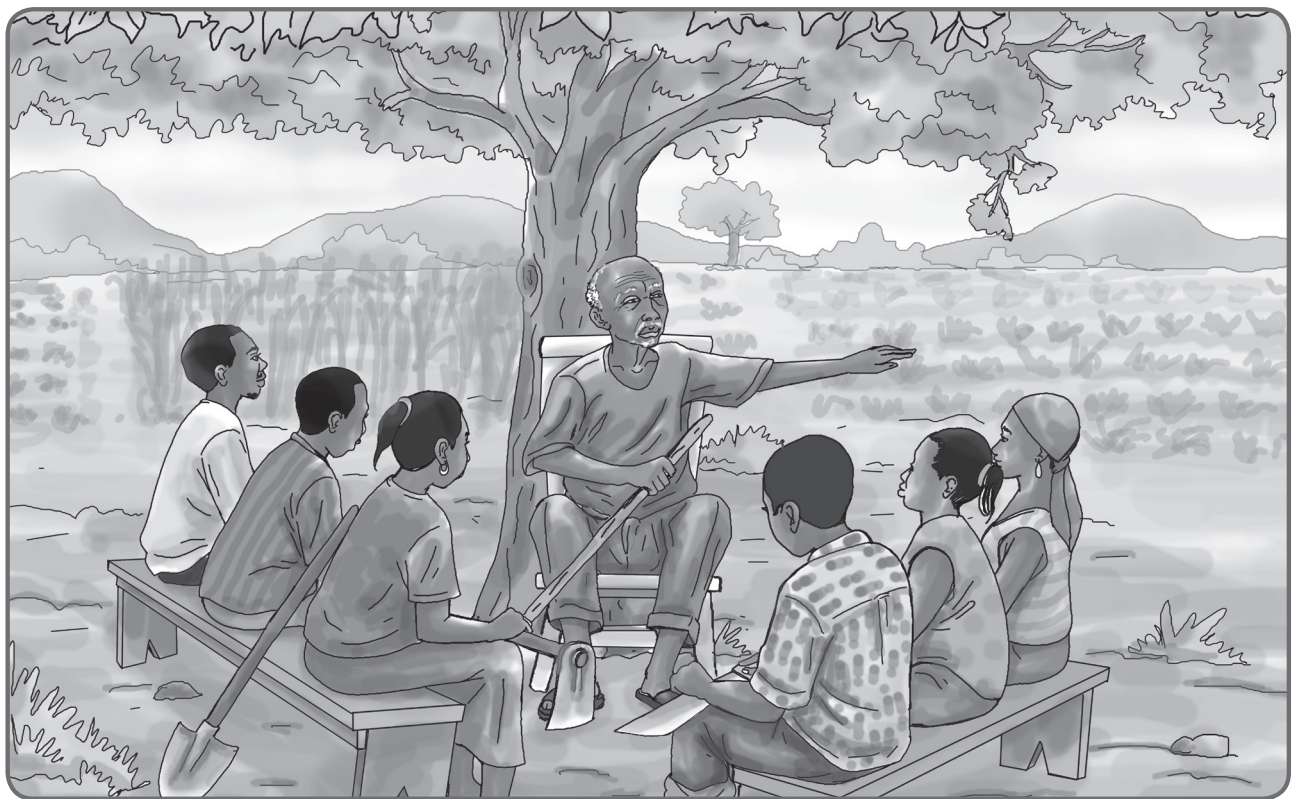



Ela kashonyi pa muaku wa pa muanda mu biambilu ebi:

1. Bidima bidi bidima mu mushipu.
2. Mamu udi usama maleyileyi.
3. Mulami ne mulongeshi badiabela Kalala.
4. Bululayi mikanda yenu .
5. Kabongo neabale makelela.

Funda mu biambilu bibidi ne muaku wa pa muanda

1. ....

2.....

Funda muaku udi kauyi pa midimu ya budimi.

mici
cisuku
nzolo
nzolo
kudima

Kumbaja ciambilu eci :

Mudimu wa budimi newukupeshe ....

Funda mu biambilu bibidi pa midimu ya madimi.

1. ....

2. ....

# Midimu

## Midimu ya bianza

Ndi njoja ne ndi ngamba.

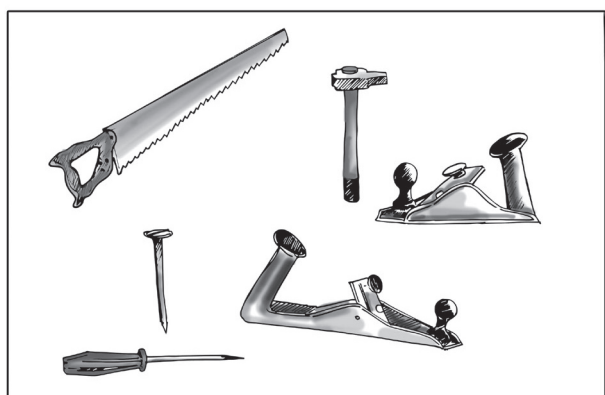
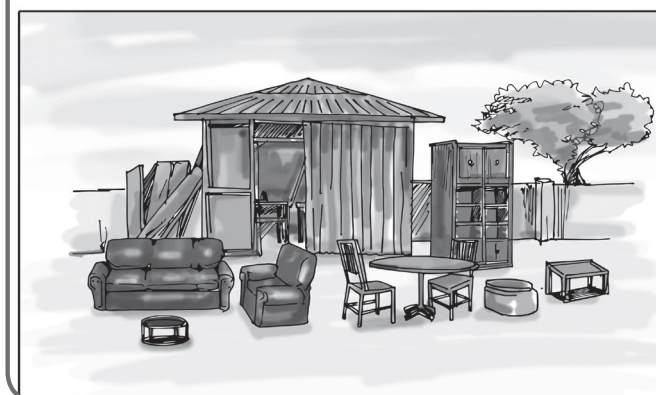
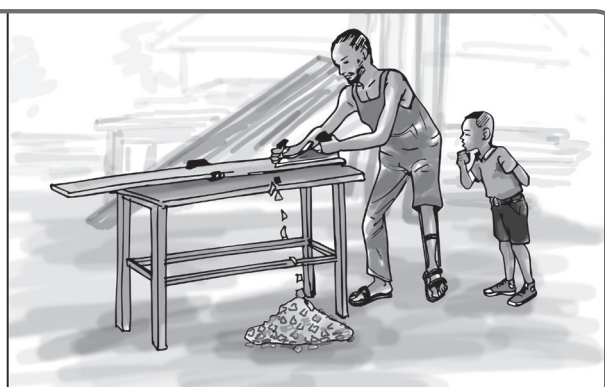
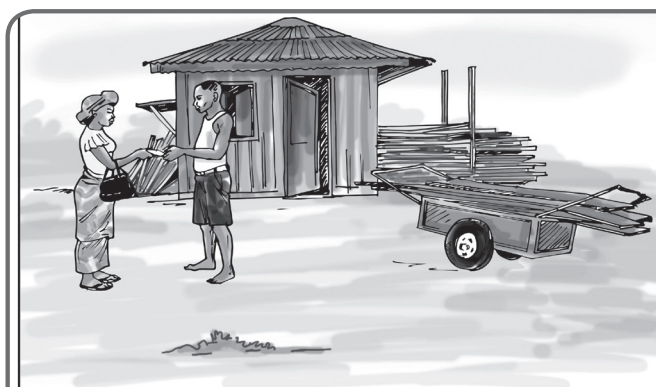





Ela kashonyi pa muaku wa pa muanda mu biambilu ebi:

1. Bidima bidi bidima mu mushipu.
2. Mamu udi usama maleyileyi.
3. Mulami ne mulongeshi badiabela Kalala.
4. Bululayi mikanda yenu .
5. Kabongo neabale makelela.

Fundayi penu biambilu bibidi ne muaku wa pa muanda:

1. ....
2. ....

Funda muaku udi kauyi pa midimu ya bianza.

kapaya
kashola
ciata
Mashinyi a bilamba
kapumbu

Kumbaja ciambilu eci :

Tuenzayi midimu ya bianza bua ...

Funda mu biambilu bibidi pa midimu ya bianza.

1. ....
2. ....

# Biambula

## Njila

Ndi njoja ne ndi ngamba.

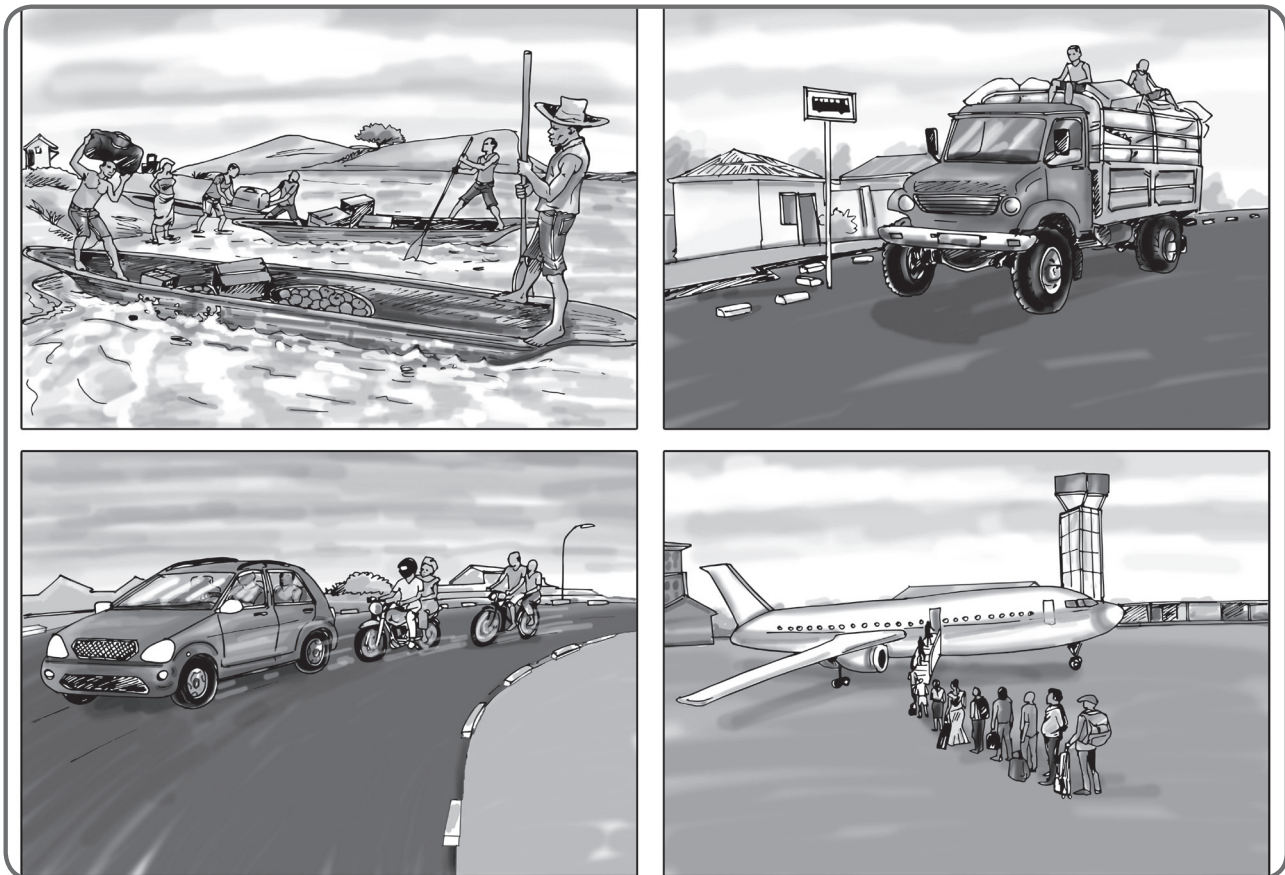



Ela kashonyi pa muaku udi uleja ngikadilu mu bia mbilu bidi bilonda ebi;

1. Kabedi udi muana mukalanga.

2. Mbua ewu udi ne lonji lukole.

3. Cilamba ciebe cidi cifike.

4. Muana ewu udi ne cibuta cikese .

5. Mashinyi a tatu adi matoke.

Tunga sasa msemua na kila elezo la hali uliocagua.

1.....

2.....

3.....

Funda muaku udi kauyi pa biambula.

Dikal
Buatu
Lukasu
Mashinyi
Kaulu

Kumbaja ciambilu eci :

Kaulu katu kendela pa .....

Funda biambilu bibidi pa mishindu ya biambula.

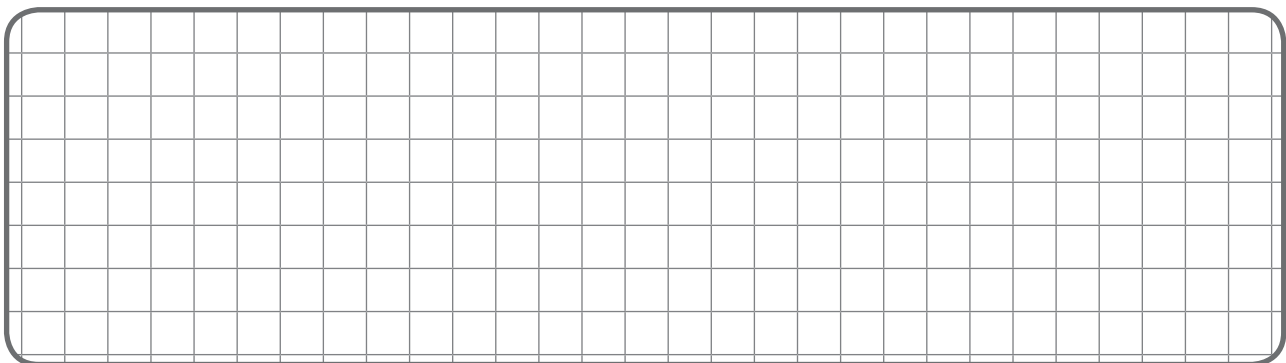

# Biambula

## Tudiendelandela

Ndi njoja ne ndi ngamba.

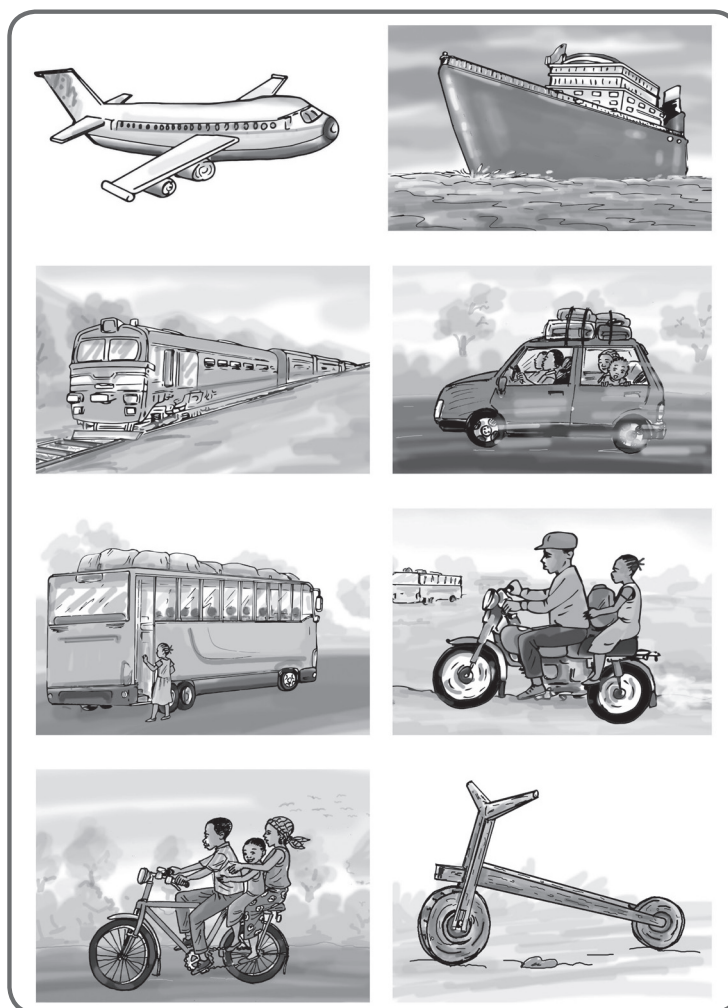





Ela kashonyi pa muaku udi uleja ngikadilu mu biambilu bidi bilonda ebi :

1. Matamba adi mushinga mutekete.
2. Nkuasa udi munene.
3. Kalala mmuvuale nzumiji mukunze.
4. Nzubu udi mule .
5. Kalasa ketu kadi kanene.

---

Fundayi penu biambilu bibidi ne muaku wa pa muanda:

1. ....
2. ....

Funda muaku udi kauyi pa biambula.

Dikalu
Buatu
Lukasu
Mashinyi
Kaulu

Kumbaja ciambilu eci :

Kaulu katu kendela pa.....

Funda biambilu bibidi pa mishindu ya biambula.

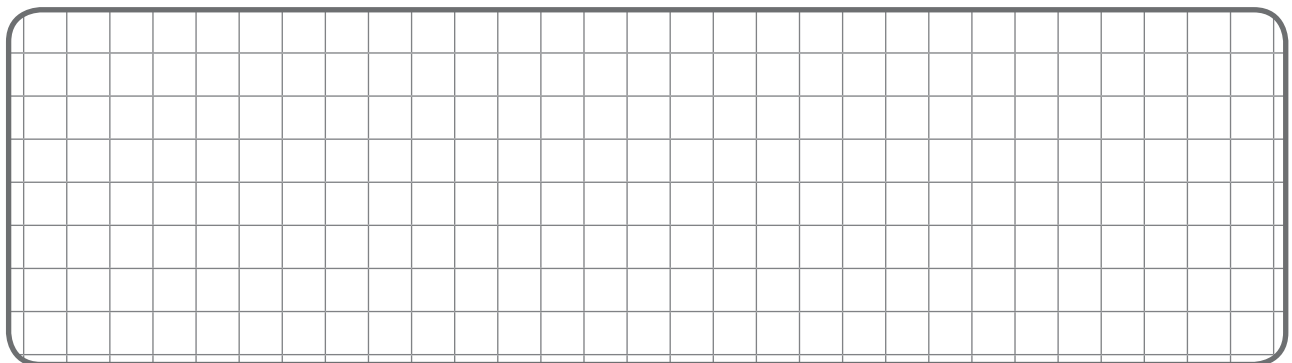

# Manaya

## Manaya a bankambua

Ndi njoja ne ndi ngamba.





Tekayi miaku eyi ku bumue anyi ku bungi :

Ku bumue	Ku bungi
Muntu	
	Bakaji
Muana	
	Bibi
Citala	

-----

Fundayi penu miaku ibidi ku bumue ne ku bungi.

1. ....
2. ....

Funda muaku udi kauyi pa biambula.

Dikal
Buatu
Lukasu
Mashinyi
Kaulu

Kumbaja ciambilu eci :

Kaulu katu kendela pa .....

Funda biambilu bibidi pa mishindu ya biambula.

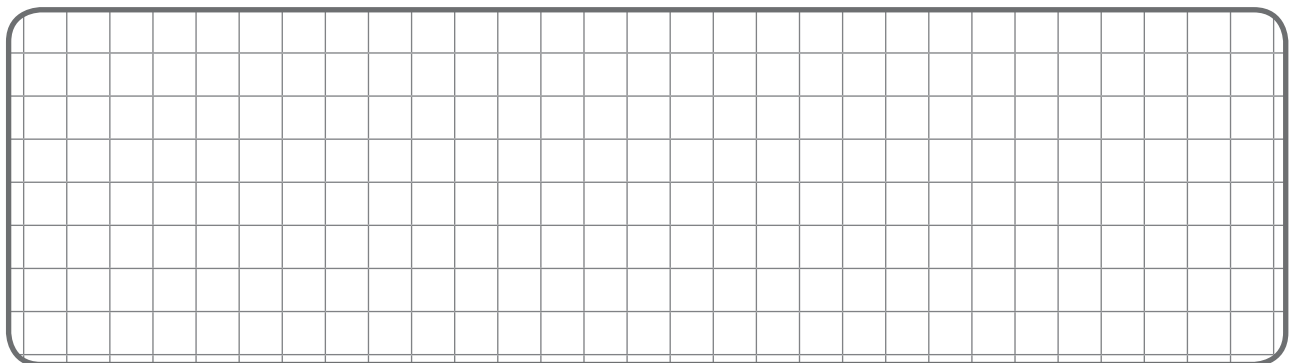

# Manaya

## Manaya a cinsangansanga

Ndi njoja ne ndi ngamba.

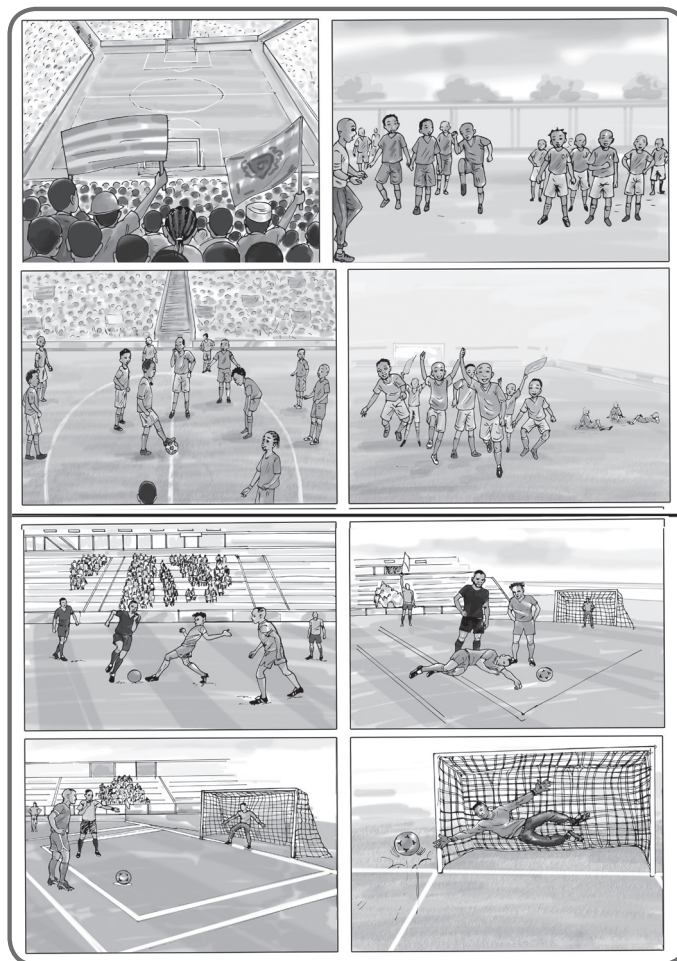





Tekayi miaku eyi bumue anyi ku bungu.

Ku bumue	Ku bungu
Ditama	
	Milangi
	Malonga
Mushete	
Dikalu	

Fundayi penu miaku ibidi ku bumue ne ku bungu.

1. ....

2. ....

Fundulula muaku udi kauyi pa manaya.

Ndundu
Tuzubu
Kaulu
Makondo
Kashiba

Kumbaja ciambilu eci

:

Kabedi udi musue kazaba kanke ne .....

Funda biambilu bibidi pa mishindu ya manaya.

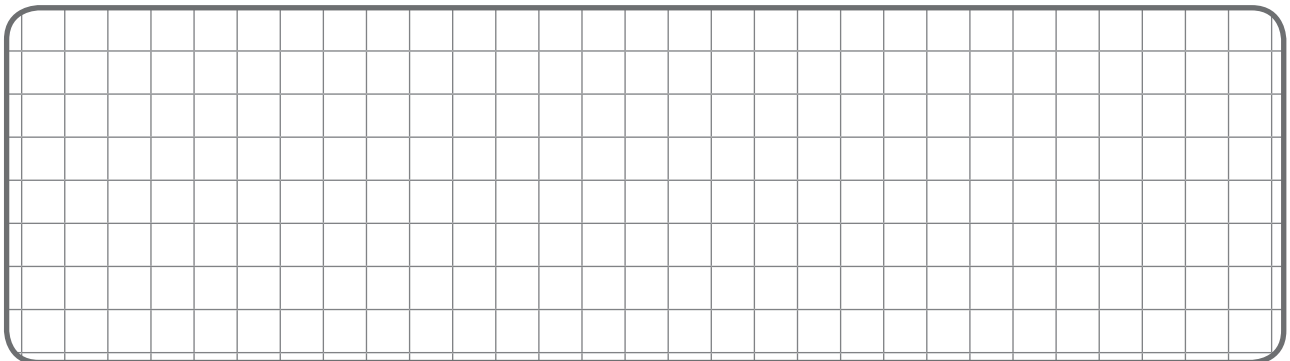

Ce manuel de l'élève a été imprimé grâce à l'appui généreux du peuple américain et du peuple britannique, à travers l'Agence des Etats-Unis pour le Développement International (USAID) et le Ministère Britannique de la Coopération Internationale (DFID/UKAID).

---



**USAID**  
FROM THE AMERICAN PEOPLE

